

### Specifications:

connector description (1)	dc plug, 6.5x3.0x24 mm, molding style, P/N 50-00090
overmold (2)	30P, PVC, black
wire description (3)	2C, 18 AWG, UL2468, 300V, 80C, 4.4 mm, VW-1, PVC, 48P, P/N 30-00007
cable outer diameter	Ø4.4 (2.2 x 2) mm
cable color	black
cable gauge	AWG #18
cable length	1830 ± 50
twist tie (4)	black, 89 ± 3

### Notes:

Function test: no open, no reversed polarity, no short circuit, no INT  
 Hi-POT test: 600 Vac, 0.5 mA, 1 sec.  
 RoHS compliant

### Mechanical drawing:

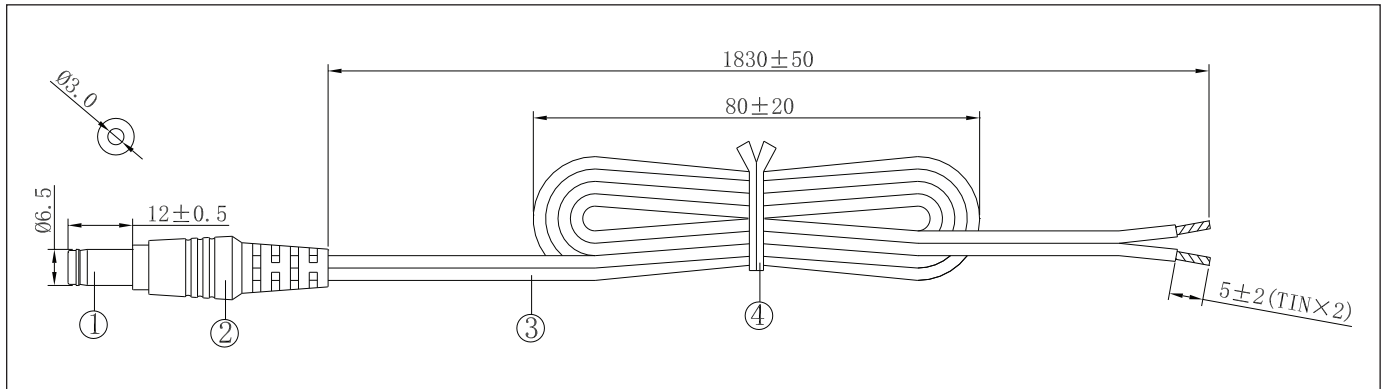

Initial

Date

tolerance X: ±0.5 mm .X: ±0.3 mm .XX: ±0.05 mm  
 applicable unless otherwise indicated in specification or on drawings

**Revision notes:**

Rev	Date	Description
A	March 29, 2010	Re-issue. Original specification issued by CUI Inc; re-issued by Tensility without any material or mechanical changes.
A1	August 31, 2011	updated description, connector, and wire information

**Specification Approval**

Spec sign-off verifies that you have reviewed the entire specification, tested a sample of the product, and confirm that it meets your requirements. This specification reflects the part as it will be ordered. Orders will not be processed until the specification pages have been initialed and the approval page has been signed. This specification is confidential and is not to be transmitted without prior approval from Tensility.

Signature \_\_\_\_\_

Title \_\_\_\_\_

Name \_\_\_\_\_

Date \_\_\_\_\_

Company \_\_\_\_\_

Branch \_\_\_\_\_