

Ratings

Voltage: 300 V
 Temperature: -40 ~ 80 °C
 Flammability: FT2

Conductor

Conductor count: 9
 Gauge: 18 AWG 0.82 mm²
 Material: bare copper strands
 Strand size: $\phi 0.127 \times 65$
 Max resistance at 20 °C: 23.2 Ω /km

Insulator

Material: TPE 85A
 Color: white, black, red, yellow, blue, green, orange, purple, gray
 Diameter: $\phi 1.8 \pm 0.10$ mm
 Nominal thickness: 0.21 mm
 Minimum resistance @ 20 °C: 100 M Ω /km

Filler

Material: cotton rope

Shield

Type: braided
 Material: bare copper strands
 Stranding: 16/5/0.10 mm, 65% minimum coverage

Drain

Material: bare copper strands
 Stranding: $\phi 0.127 \times 65$

Outer jacket

Material: TPU (Polyether Polyurethane) 80A
 Color: black
 Diameter: $\phi 9 \pm 0.20$ mm
 Nominal thickness: 0.80 mm

Wire marking: E339579 UL AWM STYLE 20280 18 AWG 80°C 300V --- cUL AWM I/II A 80 °C 300V FT2 TENSILITY

Tests

Spark test: 3.0 kV
 Insulation tensile strength: 0.562 kgf/mm²
 Jacket tensile strength: 1.05 kgf/mm²
 After aging at 113 ± 2 °C for 7 days:
 Minimum jacket tensile strength 70 % original
 Minimum insulation tensile strength 75 % original
 Minimum jacket elongation 65 % original
 Minimum insulation elongation 75 % original
 Heat shock: 121 ± 1 °C /1 hour, no observed degradation
 Deformation: 121 ± 1 °C /1 hour, ≤ 50 %
 Cold bend: -10 ± 2 °C /1 hour, no observed cracking
 Dielectric test: 2000 Vac for 1 minute without breakdown

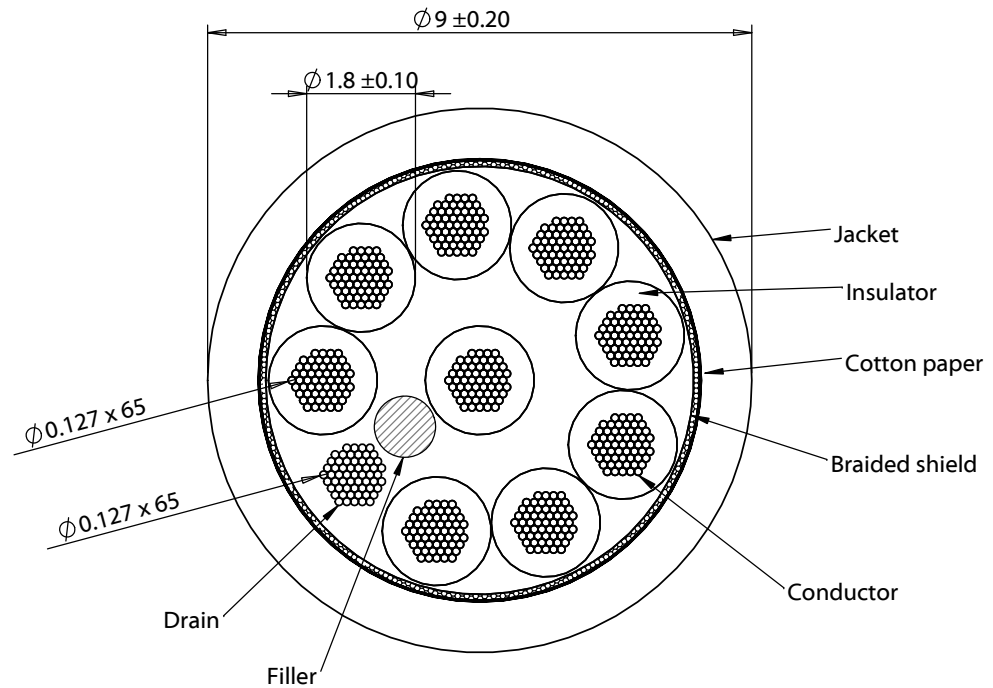
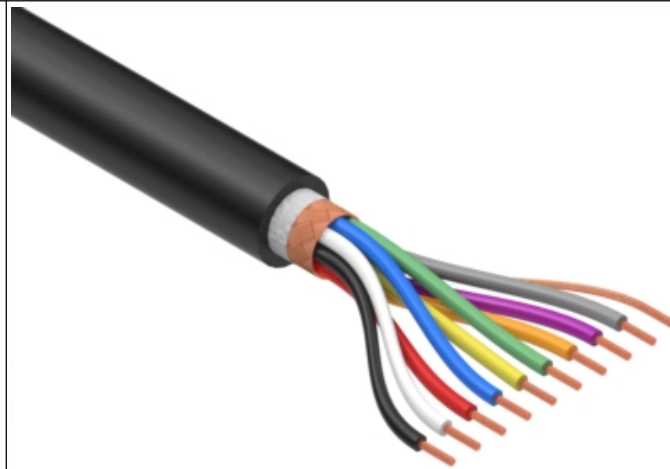

Revision:	Date:	Description:	Prepared:	Notes: RoHS and REACH compliant Phthalate and halogen free	<h1>TENSILITY</h1> <p>tel 1.541.323.3228 800 877.670.7118 fax 1.541.323.4202 web tensility.com</p>
A	6/12/2019	Initial release	Verified:		
			Dimensions are in millimeters. Tolerances: X: ± 0.5 mm X.X: ± 0.3 mm X.XX: ± 0.05 mm	Function: no open, no short circuit, no intermittent	Size: Part number: A 30-00940
				Description: Wire, 9C BC, 18 AWG, UL20280, 300V, 80C, 9.0 mm, braided shield, FT2, TPU	
					Sheet 1 of 1

5

4

3

2

1