

Specifications:

plug description (1)	Ø2.50 x 5.50 x 30 ± 0.5, black insulator, P/N 50-00011
plug overmold (2)	30P, PVC, black
cable description (3)	UL2468, 0.16 x 41 strands, twin wire
cable outer diameter	4.4 (2.2 x 2) ± 0.1
cable color	black
cable gauge	AWG #18
cable length	2000 ± 50
twist tie (4)	black, 89 ± 3
rated load	12 Vdc @ 5 A

Notes:

Function test: no open, no reversed polarity, no short circuit, no INT
 Hi-POT test: 600 Vac, 0.5 mA, 1 sec.
 RoHS compliant

Mechanical drawing:

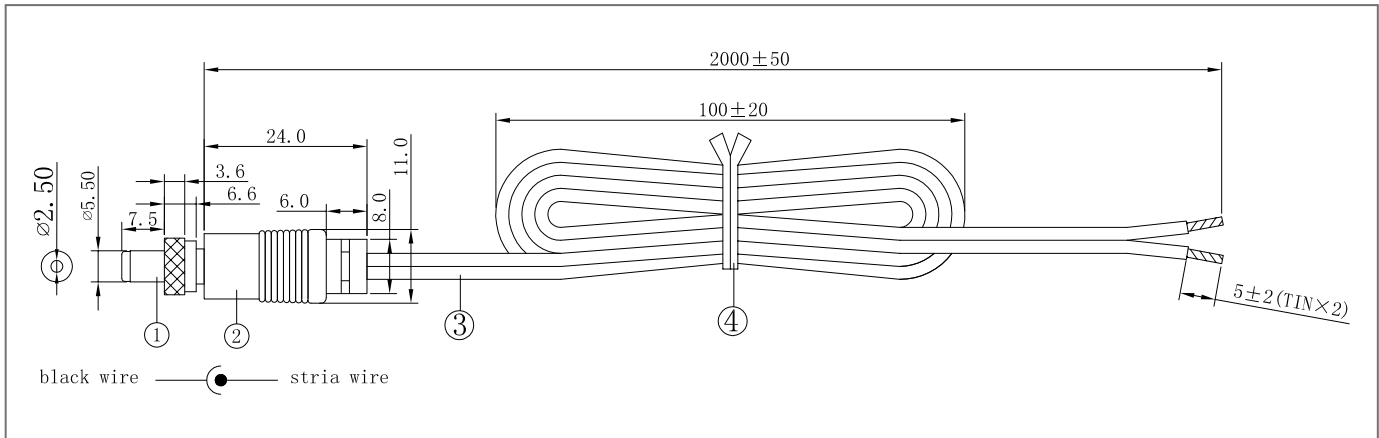

Initial

Date

tolerance X: ±0.5 mm .X: ±0.3 mm .XX: ±0.05 mm

Cable specifications:

conductors

gauge	18 AWG
material	brass copper
cord size	41/0.16 BC

jacket

material	F0068C 48PB (4026)
color	black
diameter	Ø4.4 (2.2 x 2) ± 0.10

electrical & physical properties

rated voltage	300 V
rated temperature	80 °C
insulation resistance	0.76 (15.6 °C) mΩ / m min.
resistance @ 20 °C	21.8 mΩ/m max
spark test	5.0 KV

material		insulation
unaged	tensile strength (kfg/mm ² min)	1.05
	elongation (%min)	100
aging test	condition	113°C/168 h
	elongation (% unaged min)	65
	tensile strength (% unaged min)	75
deformation (121± 1 °C x 1 hour)		≤50%
cold bend (-10 ± 1 °C x 1 hour)		OK
heat shock (121 ± 1 °C x 1 hour)		OK
flame test		VW-1

Cable cross section:

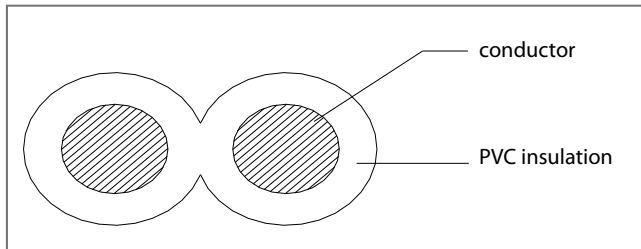

Revision notes:

Rev	Date	Description
A	May 28, 2009	initial release

Specification Approval

Spec sign-off verifies that you have reviewed the entire specification, tested a sample of the product, and confirm that it meets your requirements. This specification reflects the part as it will be ordered. Orders will not be processed until the specification pages have been initialed and the approval page has been signed. This specification is confidential and is not to be transmitted without prior approval from Tensility.

Signature _____

Title _____

Name _____

Date _____